

## SAFETY PIN BOW SHACKLE 10MM 1.0T

Brand: **Austlift**

Product Code: **503510**



GENERIC IMAGE

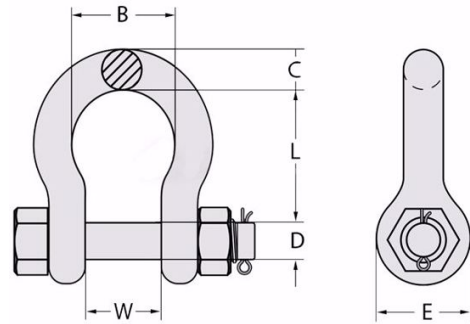

### SAFETY PIN BOW SHACKLE 10MM 1.0T

1.0T 10mm Safety Pin Bow Shackle is most commonly used for lifting applications, providing more permanent connections to Chain, Wire Rope and other rated fittings within the Marine, Agricultural, Mining and Engineering Industries. Suitable for equipment that may vibrate to ensure pin will not dislodge during use. The Safety Pin allows the pin to rotate during loading conditions.

- \* Conforms to AS2741 manufactured from Grade ?S? material in Bow configuration with Safety Pin hot dipped galvanized.
- \* Marked with working load limit in tonnes, quality grade, batch numbered, nominal size in millimeter and supplier identification.
- \* Proof tested to 2 x working load limit, with a minimum break force of 6 x work load limit.
- \* Test Certificates are available upon request.
- \* Suitable for lifting applications.

#### Specifications

|             |                 |
|-------------|-----------------|
| Dimension B | 27 mm           |
| Dimension C | 10 mm           |
| Dimension D | 11 mm           |
| Dimension E | 25 mm           |
| Dimension L | 37 mm           |
| Dimension W | 18 mm           |
| Size        | 10 mm           |
| Weight      | 0.16 kg         |
| WLL         | 1,000 kg (1.0T) |